

STK-100D-DC - CDI ignition +12v AC lighting + 12v DC battery charging

BSA: B25, B40, B44, B50, C15 | Royal Enfield 350 Bullet | Matchless 350



PRODUCT FEATURES

- Replacement for Lucas or Wipac alternator. Complete digital self generating ignition and alternator, pre-programmed advance curve gives optimum performance.
- No battery, contact breaker assembly or distributor required for the ignition.
- New simple timing set-up align marks on the rotor and stator at TDC. Rotor is supplied with a taper locking collet, enabling the rotor to be fitted on the 3/4" crankshaft without the need for a woodruff key, this allows system to be fitted even if keyway is damaged., or the shaft worn or undersize. The rotor can be fixed in any position making timing easier to set up.
- Supplied regulator/rectifier is 6v or 12v selectable by cutting the blue wire. Output is DC to charge a small battery - see notes about battery on circuit diagram (page 3). The battery can be replaced with our PP12 power pack, this is more reliable than a battery but has limited energy storage. See notes about battery on circuit diagram (page 3).
- **NOTE: A battery is NOT required to run the ignition or lighting but advantageous for brake, light operation or indicators.**
- Rotor is supplied with a taper locking collet, enabling the rotor to be fitted on the 3/4" crankshaft without the need for a woodruff key, this allows system to be fitted even if keyway is damaged. The rotor can be fixed in any position making timing easier to set up.

NOTE: for the B44/B50 and ex. WD B40, models. Modification may be required if the alternator/clutch cover has an inspection plate retained by 3 small screws. The rotor may touch one of the x3 blind threaded bosses, requiring 2-3mm of metal to be removed to give sufficient clearance. Alternatively fit a thick gasket - cork type work well and are reusable.

Fitting Instructions

- Step 1** Remove the petrol tank and seat. Remove original HT coil, rectifier & zener diode if fitted.
- Step 2** Remove LH engine cover, exposing alternator. Undo the x3 nuts holding the alternator/stator. Retain the nuts. Remove old alternator/stator from the crank cases.
- Step 3** Undo the rotor nut, this can be done by holding the rotor with a suitable tool. If an impact wrench is available it is not normally necessary to hold the rotor.
- Step 4** Fit new stator in position shown (fig. 2), use the 3 spacers supplied, on the threaded studs and use the original retaining nuts.



Troubleshooting: Stator Fouling/Hitting Drive Gear and/or Chain - see page 4 for more information

Don't fully tighten yet. Feed the stator cables through the crankcase using the original grommets as required. Feed the cables with terminals one behind the other if the hole they are passing through is very small.

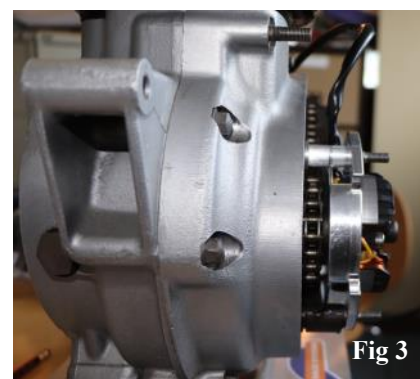

(Continued on page 2)



(Continued from page 1)

Step 5 Remove the woodruff key from the crankshaft. Locate the taper locking collet on the crankshaft as far as possible and then fit the new rotor. Ensure the rotor is not touching the stator when turned by hand. If so it may be necessary to fit a spacer/washer on the crankshaft before the taper collet is fitted. The dished part of the rotor, where the fitting nut locates, should be level with the end of the crankshaft, see Fig. 4.

Fit the original stepped nut and tighten a little so the rotor can still be moved relative to the crankshaft. We recommend using loctite on the thread to retain the nut.

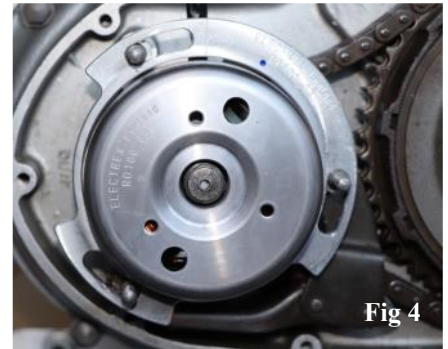

Step 6 **Setting the timing :**

Model	C15/B40	B25	B44/B50
Full advance degrees	35.5°	37°	34°
before TDC (mm)	6.5mm	7.0mm	7.7mm

Note: For singles with twin plug heads the timing can be set a few degrees retarded as the explosion in the cylinder occurs more rapidly.

Note: The new rotor R0100-03. has degree markings to make timing set-up simple. With the piston set at TDC (Top Dead Centre) align the correct degree marking, i.e. '34°' for a B50, with the blue punched dot on the stator plate, see Fig. 5. This sets the full advance to 34°. This can be checked by using a strobe light - where the 'FA' mark on the rotor should align with the red dot on the stator.

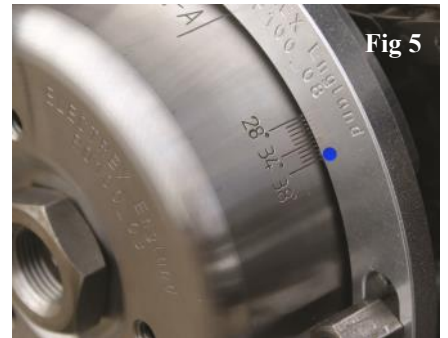

Tighten the rotor retaining nut to about 40Ft/lbs torque. Final adjustment can be made by moving the stator on the slotted holes - tighten the x3 nuts when set.

Step 7 **CDI connections** - Connect the blue, white and black cables from the stator to the corresponding coloured cables on the CDI, making sure they are in securely.

Step 8 Remove the original HT coils, the mechanical advance unit and points; these are not required for this system. The distributor, if fitted, is also not required but may wish to be retained for originality.

Step 9 Locate the HT coil in a convenient position, note the HT coil is supplied with an adaptor plate, also the HT cable can be cut to length as required. Only use the HT coil provided as this is suitable for cdi ignition, also the plug cap should be used as this is a 5k ohms resistor type and will protect the digital cdi from damage.

Step 10 Locate the CDI unit in a position to allow the orange and black wires to connect to the HT coil. The orange lead with a female 1/4 terminal is connected to the male terminal on the HT coil, the black cable with the M6 ring terminal connects to the mounting bolt for the HT coil (earth). The remaining black/white wire from the CDI is for connection to a stop/kill switch - when grounded it will cut the ignition; see circuit diagram, on next page.

Step 11 Cut the blue link wire on the regulator rectifier for 12v system. Connect the x2 yellow cables from the stator to the x2 yellow wires from the regulator/rectifier.

Battery reg/rec connections: connect the black cable to the negative terminal on the battery and the red cable to the positive.

Power pack reg/rec connections: connect the black and red cables to one set of the black and red cables on the power pack then connect yellow lighting cables to the other red cable on the power pack and the lighting earth cables to the other black cable on the power pack - Note: it doesn't matter which set of cables you use on the power pack to connect to the reg/rec or lighting.

All the power for the lighting, horn etc is taken from the battery/power pack.

Important: All additional earth cable connections need to be linked together with a cable.



STK-100D Wiring Diagram

4 stroke singles

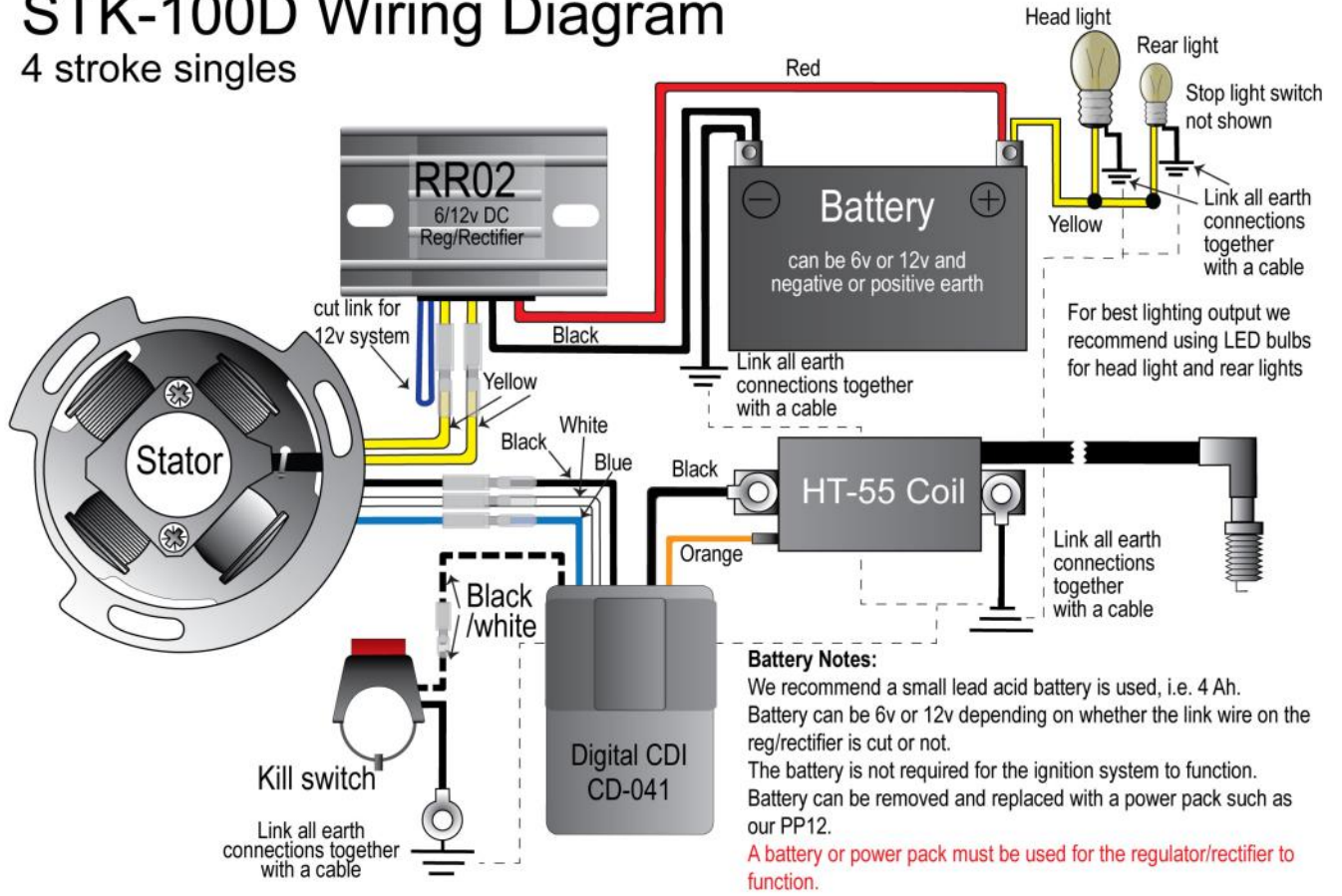

STK-100D Wiring Diagram - using our power pack

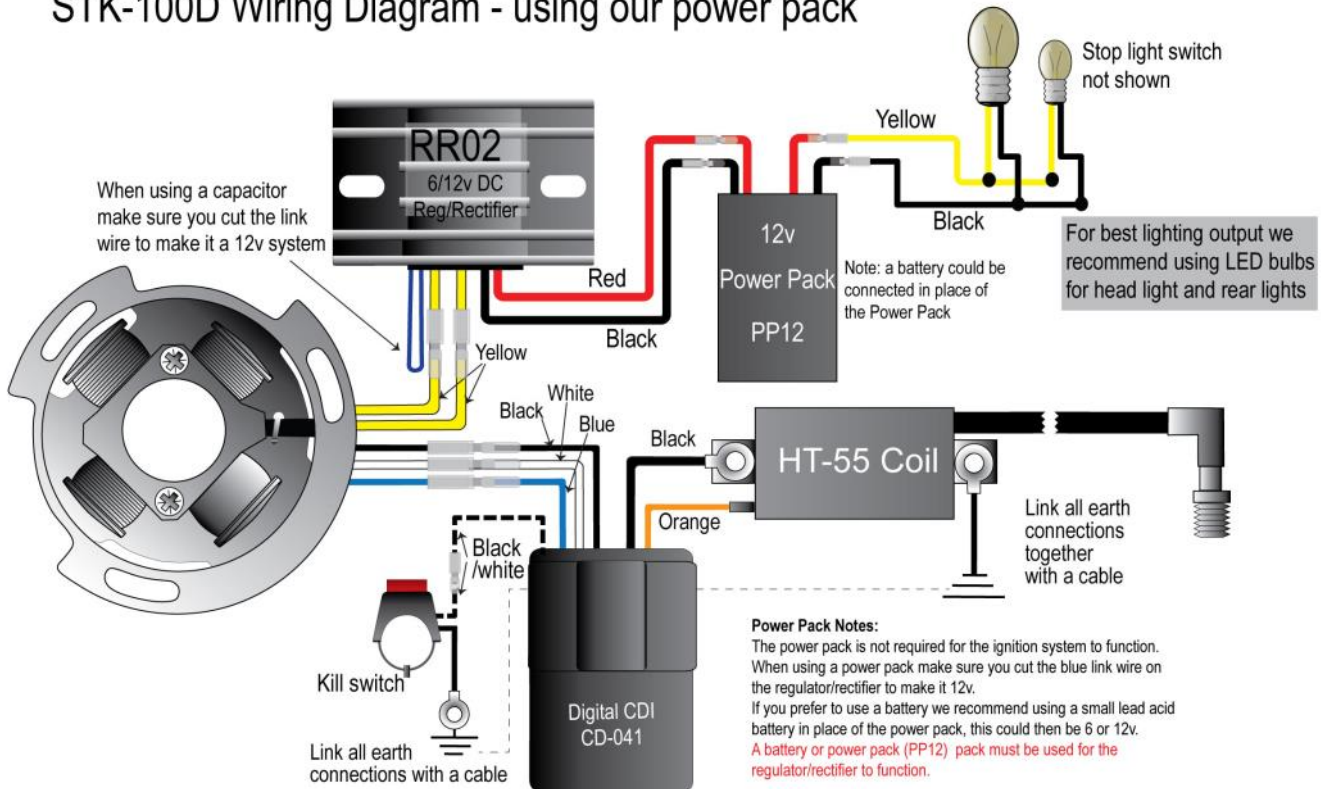



No Spark visible on kick over.

- A spark isn't always visible when kicking the bike over and this is normal. The CDI produces a high voltage short duration spark, this intensifies as RPM increases, as opposed to points which produce a low voltage long duration spark.
- Check resistance of source coil on stator, this should read approx. 270-300 ohms between the blue and white cables.
- Disconnect the Black/White wire from the kill switch for testing.
- Plug gap 0.4 - 0.6mm.
- All terminal connections need to be tight.
- HT-coil - primary resistance terminal to earth on coil 0.5ohms, HT lead to earth.

Stator fouling/hitting drive gear and/or chain and/or rotor fouling/hitting stator.

Ensure stator is fitted in the correct orientation. Check the stud and thread lengths on the studs, these can vary and may have been replaced during the life of the bike. When new these would have been, stud length including thread measured from the casing, all 3 studs being 48.5mm, threaded portion being 14.5mm. If your measurements vary from these then additional or fewer spaces/washers will be needed in order to get the correct clearances.

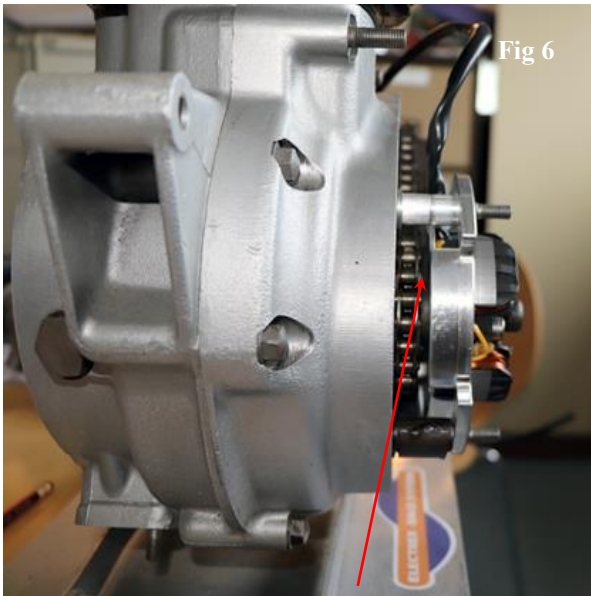

The stator needs to fit flat and square to the shaft as near as possible to the primary drive chain without touching it. .

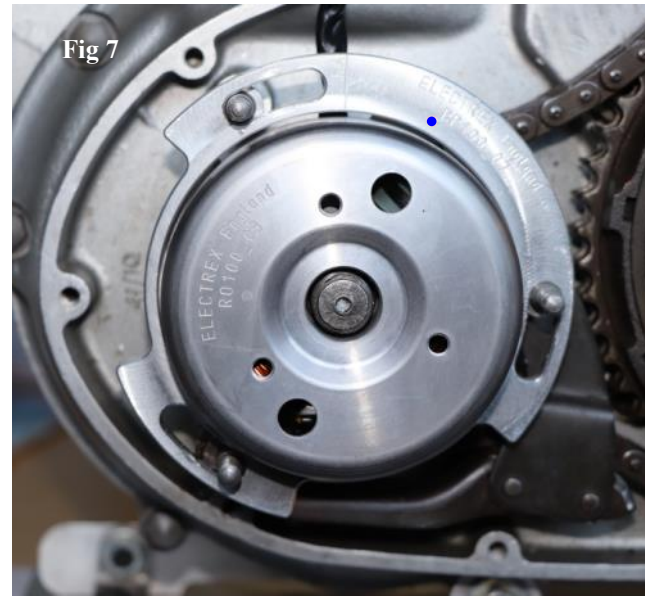

Ensure the stator is mounted in the correct orientation to allow easy cable feed through the engine. On a B40 the cable feed hole is at the top as shown in fig 7 above.